



DIMENSIONAL DRAWINGS

HOUSED RESOLVERS SERIES R 11

- Brushless construction
- Maintenance free
- Able to withstand high shock and vibration levels
- Impervious to most industrial contaminant and temperature extremes
- High temperature up to 115°C

Housed Resolvers distinguish themselves through high reliability in harsh environments, operating temperatures up to 155 °C and high shock resistance. Based on their brushless design they are the ideal supplement to brushless servo motors. The accuracy as well as the repeatability are excellent. These resolvers are equipped with precision bearings and are maintenance-free. They are also the shortest resolvers, that are available on the market.

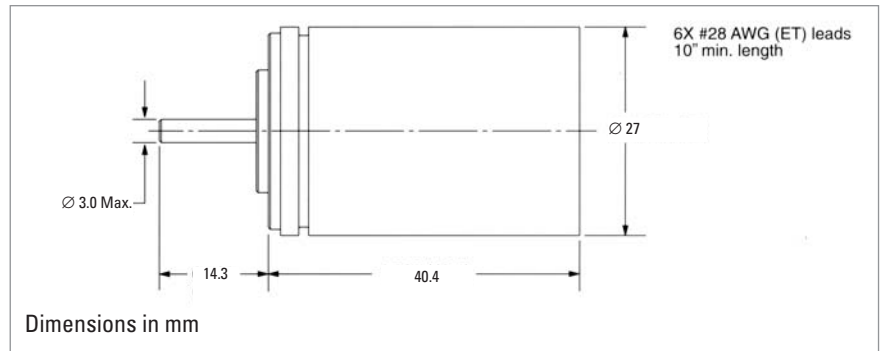

DIMENSIONAL DRAWINGS

HOUSED INDUSTRY RESOLVERS SERIES R 25

- Rugged housing with IP65
- Able to withstand high shock and vibration levels
- Impervious to most industrial contaminant and temperature extremes
- High temperature up to 125°C
- Flange- and servo-mount styles

Industry resolvers possess especially robust casings with protection class IP65. They are especially suitable for the use with high temperatures (+125 °C in long-term operation), and offer extraordinary values of vibration and shock resistance (40g as well as 200g), as well as noise immunity. The user is flexible in the application because of the corrosion resistant versions for integration or extension, the connection could easily be done by Standard MS-style connectors. The accuracy has a spread of ± 7 up to ± 200 arc-minutes.

