

TECHNICAL DATASHEET

HD - Incremental Encoders HSD 37



- Single or Dual Output
- Double-Sealed Housing
- ATEX Certification for Intrinsically Safe Applications
- High Resolution Unbreakable Disk
- Electrically and Thermally Isolated
- Industrial Duty Connector
- NEMA 4X, 6 / IP66, 67 Rated
- Rugged Cast-Aluminum Housing
- Stainless Steel Housing Available

HEAVY DUTY

NorthStar™ **CE**

NUMBER OF PULSES

0015 / 0032 / 0100 / 0200 / 0240 / 0250 / 0500 / 0512 / 0600 / 1000 / 1024 / 1200 / 2000 / 2048 / 2500 / 4000 / 5000

GENERAL INFORMATION

EXTREME HEAVY DUTY HOLLOWSHAFT ENCODER

NorthStar's HSD37 Extreme Duty Industrial Hollowshaft Encoder accepts up to 1" diameter shafts and operates reliably from -40 to +100°C. Its Hard Anodized finish enclosure exceeds IP66/IP67 and NEMA 6 enclosure requirements.

This robust encoder features a double-sealed housing that allows application where regulatory washdown or caustic chemicals are present. Utilization of an advanced Opto ASIC with innovative packaging techniques enables the encoder to operate in high shock and vibration environments.

It is also available in an Intrinsically Safe version, certified to ATEX EEx ia IIB T4, when used with the appropriate IS Barrier.

APPLICATIONS

The HSD37 extreme duty encoder features simple installation on motor or machine shafts. It is often mounted on the back of motors where encoder feedback is needed in harsh environment applications. It is ideal for use in environments that demand heavy washdown protection.

- Converting Machinery
- Material Handling
- Packaging Equipment
- Processing Equipment

Industries

Chemical, Food & Beverage, Oil & Gas, Paper, Steel and any other where a precise encoder is needed to operate in harsh environments.

**TECHNICAL DATA
mechanical**

Housing diameter	95.25 mm
Shaft diameter	12 mm / 1/2" / 15 mm / 5/8" / 16 mm / 3/4" / 0.875" (Through hollow shaft)
Flange (Mounting of housing)	Tether
Mounting of shaft	Front clamping ring
Protection class shaft input (EN 60529)	NEMA 4X or NEMA 6 IP66 or IP67

TECHNICAL DATASHEET

HD - Incremental Encoders HSD 37

TECHNICAL DATA mechanical (continued)

Protection class housing (EN 60529)	NEMA 4X or NEMA 6 IP66 or IP67
Shaft tolerance	31,75 mm
Bearing life	max. 5 x 10 ¹¹ revs.
Torque	2.8 Ncm
Vibration resistance (DIN EN 60068-2-6)	200 m/s ² (5 ... 2000 Hz)
Shock resistance (DIN EN 60068-2-27)	500 m/s ² (11 msec)
Operating temperature	-40 °C ... +100 °C ATEX: -40 °C ... +80 °C
Material shaft	Aluminum
Material housing	Hard anodized Aluminum, Stainless Steel
Weight	approx. 1000 g
Connection	MS, radial Cable, radial with M12 connector

TECHNICAL DATA electrical

Supply voltage	DC 5 - 26 V
Max. current w/o load	50 mA
Code	Incremental, optical
Max. pulse frequency	125 kHz
Phasing	Incremental signals (A leads B): A leads B by 90° for ccw shaft rotation viewing the shaft clamp end of the encoder
Pulse shape	Square wave

ELECTRICAL CONNECTIONS 6, 7 & 10 Pin MS connector / Cable

Encoder Function	Cable 6 Pin Single Ended		Cable 7 Pin Single Ended		Cable 7 Pin Dif Line Drv w/o Idx		Cable 10 Pin Dif Line Drv w/ Idx		Cable Exit with Seal
	Pin	Wire Color	Pin	Wire Color	Pin	Wire Color	Pin	Wire Color	Wire Color
Sig. A	E	brown	A	brown	A	brown	A	brown	green
Sig. B	D	orange	B	orange	B	orange	B	orange	blue
Sig. Z	C	yellow	C	yellow	--	--	C	yellow	orange
Power +V	B	red	D	red	D	red	D	red	red
Com	A	black	F	black	F	black	F	black	black
Case	--	--	G	green	G	green	G	green	white
N/C	F	--	E	--	--	--	E	--	--
Sig. \bar{A}	--	--	--	--	C	brown/white	H	brown/white	violet
Sig. \bar{B}	--	--	--	--	E	orange/white	I	orange/white	brown
Sig. \bar{Z}	--	--	--	--	--	--	J	yellow/white	yellow

TECHNICAL DATASHEET

HD - Incremental Encoders HSD 37

ELECTRICAL CONNECTIONS 5 & 8 Pin M12 Accessory Cable

Encoder Function	Cable 5 Pin Single Ended		Cable 8 Pin Single Ended		Cable 8 Pin Differential	
	Pin	Wire Color	Pin	Wire Color	Pin	Wire Color
Sig. A	4	black	1	brown	1	brown
Sig. B	2	white	4	orange	4	orange
Sig. Z	5	grey	6	yellow	6	yellow
Power +V	1	brown	2	red	2	red
Com	3	blue	7	black	7	black
Sig. \bar{A}					3	brown/white
Sig. \bar{B}					5	orange/white
Sig. \bar{Z}					8	yellow/white

DIMENSIONED DRAWINGS

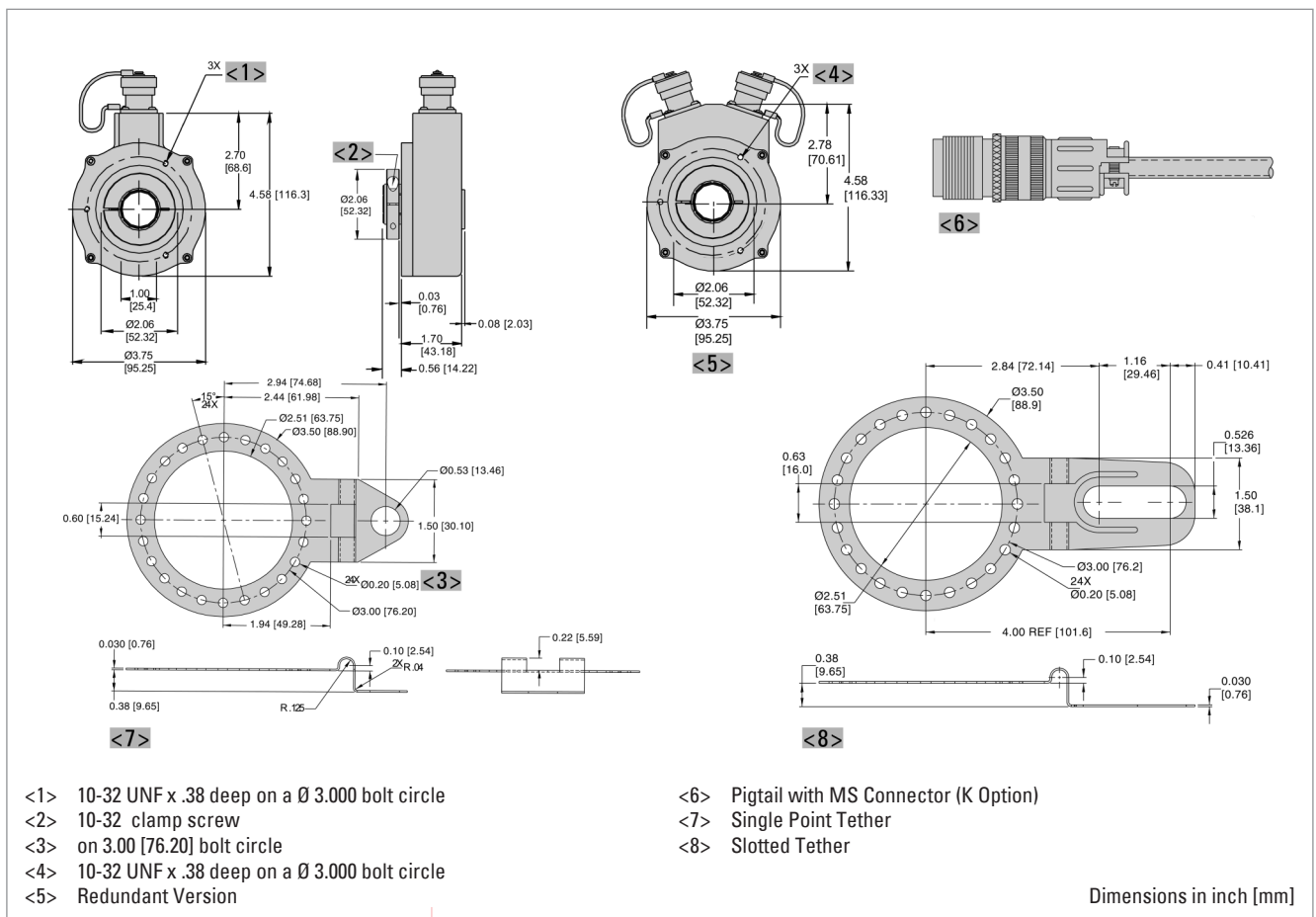

TECHNICAL DATASHEET

HD - Incremental Encoders HSD 37

ORDERING INFORMATION

Type	Number of pulses	Shaft Ø	Format ^{4,5}	Output	Connection ⁶	Safety ^{1,2,3}	Housing, Tether, Options
<input type="checkbox"/>	<input type="checkbox"/>	<input type="checkbox"/>	<input type="checkbox"/>	<input type="checkbox"/>	<input type="checkbox"/>	<input type="checkbox"/>	<input type="checkbox"/>
HSD37	15 ... 5000	6 12 mm 7 12.7 mm (1/2") 8 5/8" 9 15 mm A 16 mm C 3/4" E 7/8" G 1"	0 single ended, unidirectional (A) 1 single ended, bidirectional (AB) 2 single ended, bidirectional with index (ABZ) 3 differential, bidirectional (A-A B-B) 4 differential, bidirectional with index (A-A B-B Z-Z)	0 5-26V in, 5-26V Open Collector out (7273) 2 5-26V in, 5-26V Push-Pull out 3 5-26V in, 5-26V Differential Line Driver out (7272) 4 5-26V in, 5V Differential Line Driver out (7272)	0 6 pin connector 1 7 pin connector 2 10 pin connector 5 6 pin connector plus mating connector 6 7 pin connector plus mating connector 7 10 pin connector plus mating connector A Cable, 0.5 m H M12 connector, 5 pole J M12 connector, 8 pole K 0.5 m cable with 10 pin in-line connector L Cable, 0.91 m M Cable, 1.52 m N Cable, 3.05 m	0 No ATEX 1 ATEX Type 1 Option 2 ATEX Type 2 Option 3 ATEX Type 3 Option	0 Cast Aluminum Housing, Slotted Tether 2 Stainless Housing, slotted tether 3 Redundant Outputs (Dual Connector Housing), slotted tether 5 Stainless Housing, Redundant Outputs, slotted tether C Cast Aluminum Housing, Single-Point Tether Included (NEMA 4.5" C-face) E Stainless Housing, single-point tether F Redundant Outputs (Dual Connector Housing), single-point tether H Stainless Housing, Redundant Outputs, single-point tether 6 Same as "0" but no tether 8 Same as "2" but no tether 9 Same as "3" but no tether B Same as "5" but no tether

¹ ATEX Type 1: 5 V in, 5 V out

ATEX Type 2: 7-26V in, 7-26V out

ATEX Type 3: 7-26V in, 5V out

² Safety Code "2" not available in combination with Output Code "4"

³ Safety Code "3" only available with Output Code "4"

⁴ Format Code "3" only available with Code "3" or "4"

⁵ Format Code "4" only available with Output Code "3" or "4" resp. Connection Code "2", "7", "J", "K", "L", "M", "N" or "A"

⁶ Connection Code "H" only available with Code "0" or "2"