

for AC Synchronous & BLDC Motors



- Compact hollowshaft motor encoder, ideal for BLDC, DC-Servo and Stepper feedback
- Resolver compatible mounting
- Resolution up to 2048 ppr
- Operating temperature up to 120 °C
- Frequency response to 300 kHz
- Mounting depth 22.4 mm

GENERAL INFORMATION

The type F21 encoder provides high performance, cost effective feedback for stepper and servo motor applications. The F21 offers compact package dimensions and flying leads for a low-profile installation. A size 21 servo ring allows easy mounting and replacement of pancake resolvers with high tolerance to motor shaft movement and 360 degrees of adjustment to align the signal outputs to the shaft position.

NUMBER OF PULSES

1024, 2048;
optional additional 6, 8, 10, 12 or 16 pole commutation signals

TECHNICAL DATA
mechanical

Weight approx.	90 g
Dimensions	Outside diameter: 52.4 mm max.; Height: 25.7 mm max.
Material	Housing: cast-aluminium; Servo ring: aluminium; Hub: brass; Disk: 0.76 mm thick glass
Moment of inertia	2.5 gcm ²
Hollow shaft diameter	12.7 mm
Hollow shaft balance	+0.001"/-0.000" (+0.025 mm/-0.000 mm)
Radial runout of mating shaft	±0.05 mm max. (includes shaft perpendicularity to mounting surface)
Axial endplay of mating shaft	±0.25 mm max.
Mounting	2.062" (52.4 mm) flexible servo ring (size 21 pancake resolver equivalent)
Acceleration	100 000 rad/s ² max.
Max. speed	5 000 min ⁻¹ continuous; 12 000 min ⁻¹ peak
Bearing life	[(3.6 x 10 ⁹) / RPM] hours; e.g. 605 000 hours at 6 000 RPM
Operating temperature	0° ... +120 °C
Storage temperature	0° ... +120 °C
Shock resistance	50 g for 6 ms duration
Vibration resistance	2.5 g at 5 to 2 000 Hz
Relative humidity	90 % non-condensing

for AC Synchronous & BLDC Motors

TECHNICAL DATA
electrical

Code	Incremental with commutation, optical	
Supply voltage	DC 5 V ±10 % DC	
Max. current w/o load	Incremental and commutation: 100 mA max.	
Output circuit		
Incremental	26LS31 differential line driver, 40 mA max.	
Commutation	Open Collector, max. 8 mA; Pull-up 2.0 KΩ or 26LS31 differential line driver, 40 mA max.	
Output signals		
Incremental	RS 422: A, B, N, \bar{A} , \bar{B} , \bar{N}	
Commutation (optional):	O.C: U, V, W	RS 422: U, V, W, \bar{U} , \bar{V} , \bar{W}
Accuracy		
Incremental signals	+/- 2.5 arc-mins. max. (edge to any edge)	
Commutation signals	+/- 6 arc-mins. max.	
Phasing	A leads B by 90° and U leads V leads W by 120°	
Minimum edge separation	A to B is 45°	
Index to U channel	+/- 1° mech. index pulse center to U channel edge (see signal diagram)	
Index pulse width	90° gated A and B high	
Max. output frequency	300kHz, max.	
Connection	Flying leads, ...	

DIMENSIONAL DRAWINGS

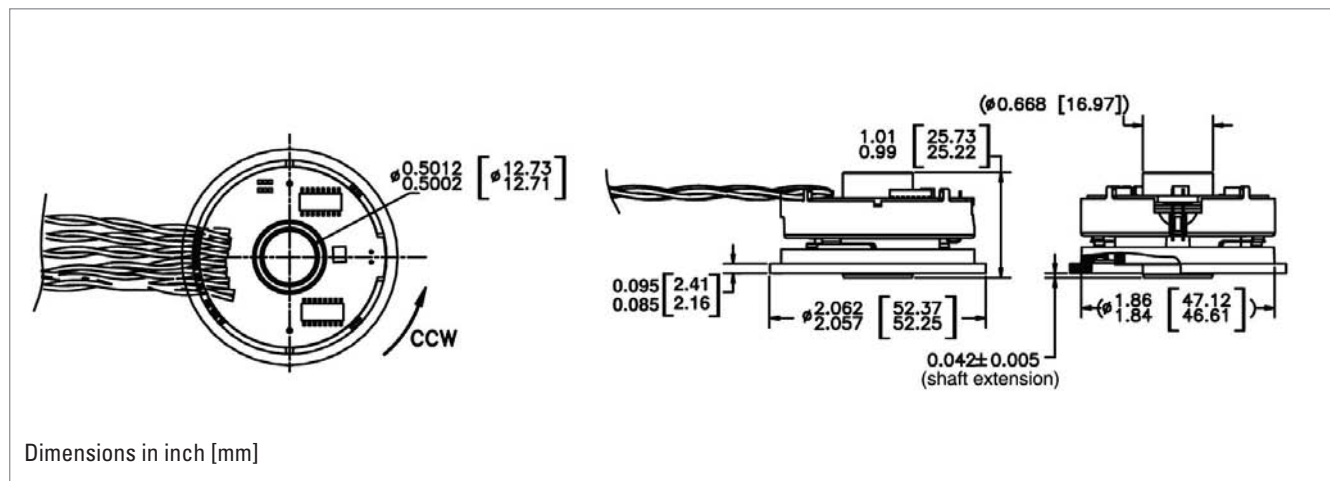

for AC Synchronous & BLDC Motors

SIGNAL DIAGRAM

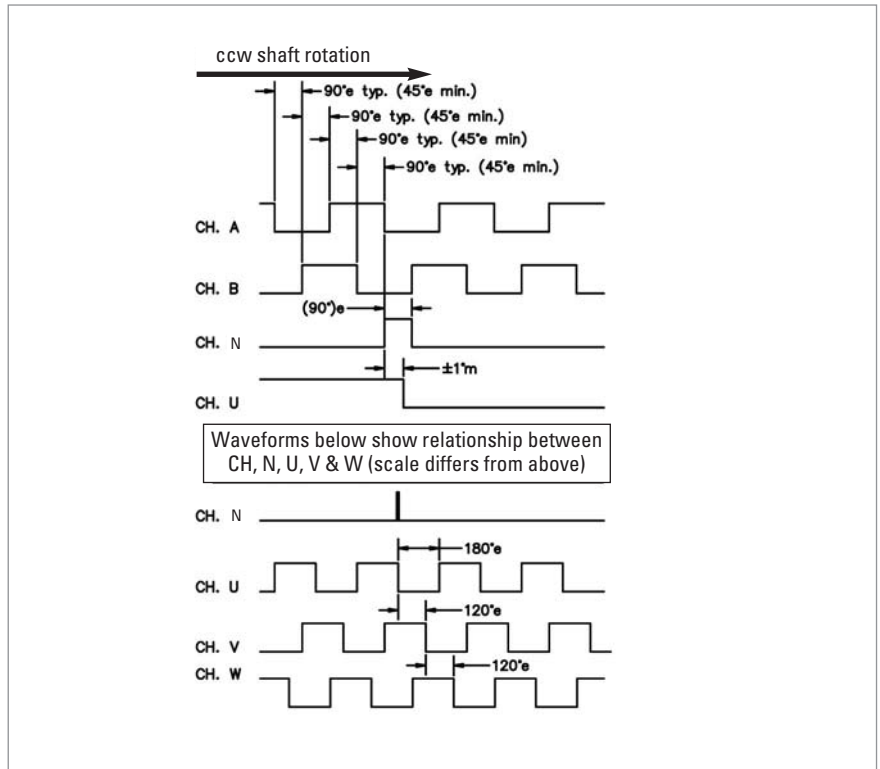

CONNECTION DIAGRAM

Function ¹	Colour
VCC	red
GND	black
\bar{A}	blue/black
A	blue
\bar{B}	green/black
B	green
\bar{N}	violet/black
N	violet
\bar{U}	brown/black
U	brown
\bar{V}	grey/black
V	grey
\bar{W}	white/black
W	white

¹ availability of function depends on version

for AC Synchronous & BLDC Motors

ORDERING INFORMATION

Type	Pulses ppr incremental ²	Poles commutation ²	Mounting	Electrical ¹	Shaft / Bore	Connection
<input type="checkbox"/>	<input type="checkbox"/> / <input type="checkbox"/>	<input type="checkbox"/> - <input type="checkbox"/>	<input type="checkbox"/>	<input type="checkbox"/>	<input type="checkbox"/>	<input type="checkbox"/>
F21-	1 024 2 048	0 without 6 6 pole 8 8 pole C 10 pole E 12 pole I 16 pole	0 Servo ring size 21	incremental only without commutation 3 $U_{inc}=DC\ 5\ V$; output _{inc} =RS 422 incremental plus commutation signals 6 $U_{inc}=DC\ 5\ V$; output _{inc} =RS 422, $U_{com}=DC\ 5\ V$; output _{com} =NPN-O.C. 9 $U_{inc}=DC\ 5\ V$; output _{inc} =RS 422, $U_{com}=DC\ 5\ V$; output _{com} =RS 422	3 12.7 mm through bore	0 16.5 cm Flying leads
¹ U_{inc} : Supply voltage incremental, U_{com} : Supply voltage commutation (only if commutation is selected) ² allowed combinations see available combinations (pulses/poles)						

Available combinations (pulses/poles)

Pulses ppr	Number of poles					
	0	6	8	10 (=C)	12 (=E)	16 (=I)
1024	X	X	X	X	X	X
2048	X	X	X	X	X	X